

Ayrton: Cobra/Rivale (2)

Zub.-Fach, HH=0, Vers. BT Innotec



- Profi-Version aus 10mm Birkensperrholz
- Folienbeschichtung in 18 wählbaren Farben
- Heavy Duty Beschläge
- Original amptown cases Blue Wheels



580
SEITENANSICHT

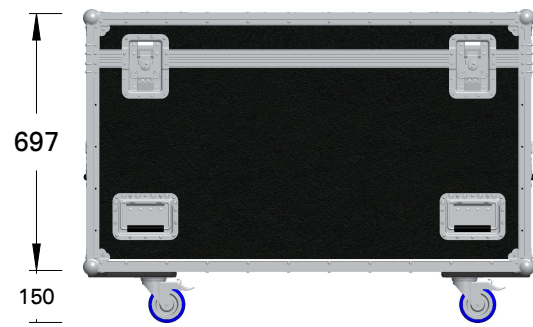

697
150
1200
FRONTANSICHT

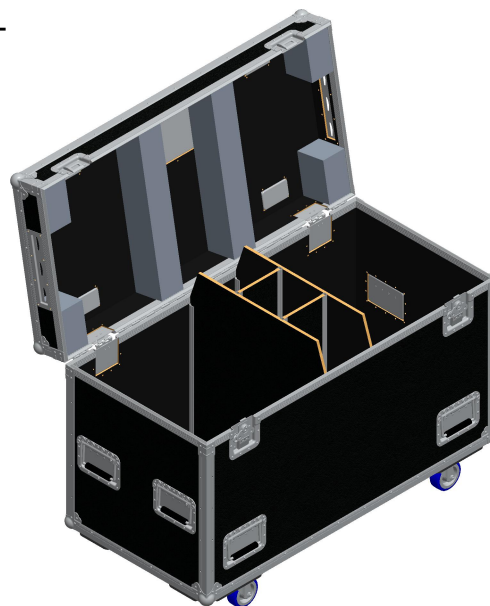

CASE GEÖFFNET

FLIGHTCASE HOLZZUSCHNITT

FCP 10 mm Casefarbe

2 x 1200 x 579	Deckel-/Bodenplatte
2 x 1200 x 110	Deckel vorn/hinten
2 x 1200 x 555	Korpus vorn/hinten
2 x 560 x 110	Deckel seitlich
2 x 560 x 555	Korpus seitlich

DETAILS/OPTIONEN

stapelbar (BuPla)
LabelDish 2116
Dopp. Boden im Zub.-Fach
LüGi Penn G1560z (2)

BT Innotec

Hersteller

Ayrton

Artikel

Cobra/Rivale (2)
Zub.-Fach, HH=0

EINBAUTEN

10mm besch.	
2 x 557 x 665	TW quer bis DE
2 x 168 x 378	(h)
18mm besch.	
1 x 566 x 180	Dopp. Boden

Rüchwand

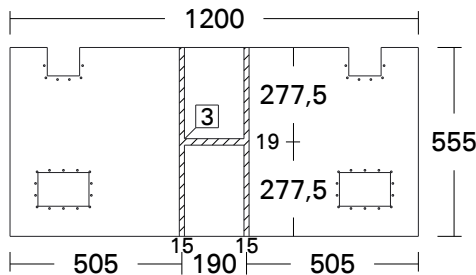

SCHAUMSTOFF

H-90	
4 x 110 x 150	Deckel_Ecken
H-90	
2 x 110 x 560	Deckel

U-Profil	
4 x 535	4 x 378

Kante 35mm

4 x 1190	4 x 95
4 x 570	4 x 540
x	

1 x 758 Haubenband

Verschluss	Anschlag	
Catch	2 gross	110
	davon 0 abschliessbar	
Aufsteller	Anschlag	
gross	2	110
Griff		
Handle	8 gross	
Rollen		
100 BW	4	RPG 235
	davon 2 Stop	

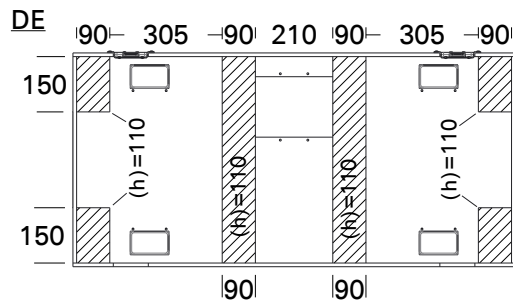
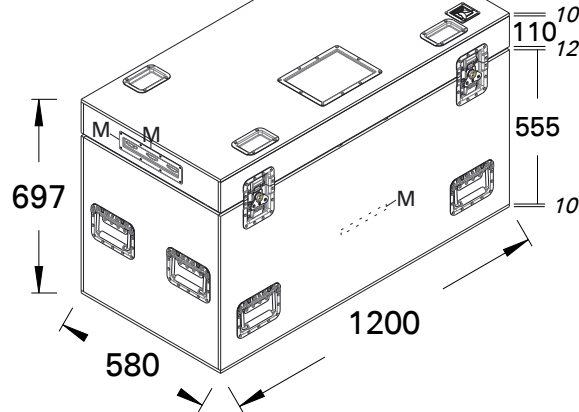

UT

TW bis Deckel
(offene Kanten
rund + SZ)

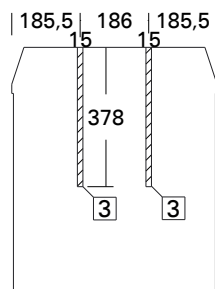
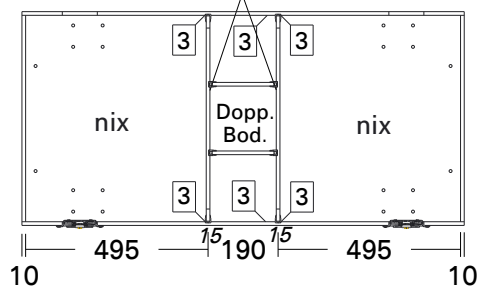

TW
Zub.-Fächer auf
dopp. Boden

Anzahl:	Farbe:	Kunde:	AB:
---------	--------	--------	-----

X
FCP
FCS

DATUM

Plan vom
23.11.2023
letzte Änderung vom
24.11.2023

Gewicht:	Produktionstermin:	Liefertermin:
54kg		

